

## 15. DRIVE SHAFT

15-1.	Description . . . . .	15-2
15-2.	Dismounting. . . . .	15-3
15-3.	Disassembly . . . . .	15-5
15-4.	Maintenance Services . . . . .	15-7
15-5.	Installation Procedure . . . . .	15-7

## 15-1. Description

The drive shaft joint is a constant velocity joint (C.V. joint) which slides in the axial direction. The joint is composed of an outer race, cage, inner race and balls. In the turning direction, the joint rotates in the same way as a ball bearing. The 6 balls lock rotation completely and transmit drive. In addition, this vehicle is also characterized by a function that the shaft can slide through the balls in the grooves of the outer race in the extension/contraction direction of the drive shaft.

### Major characteristics

1. Being a complete constant velocity joint, the joint ensures smooth rotation of drive shaft.
2. Small drive shaft sliding resistance reduces the effect of engine vibration on the chassis.
3. Excellent durability.

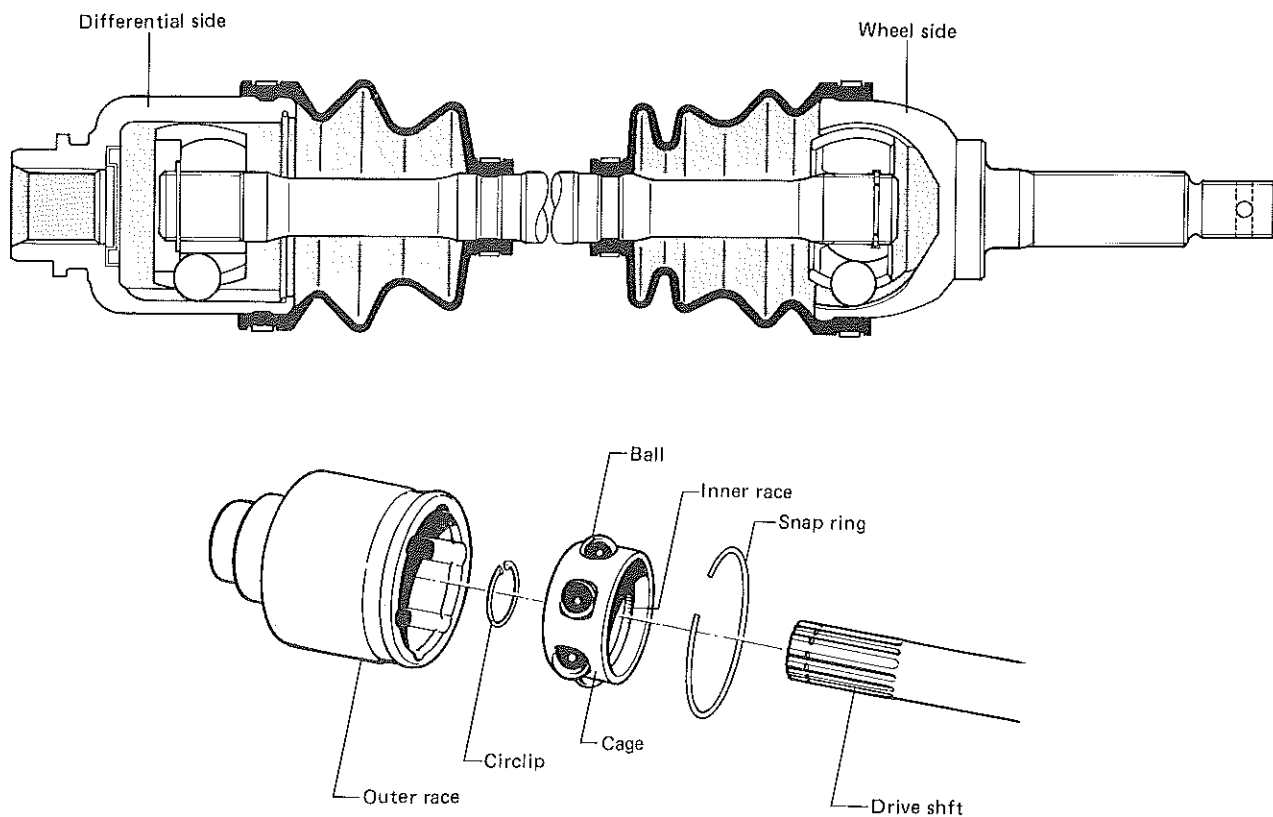

Fig. 15-1

## 15-2. Dismounting

- 1) Lift the front end of the machine by jacking after loosening hub nuts, and support it with safety stands.
- 2) Take off a wheel.

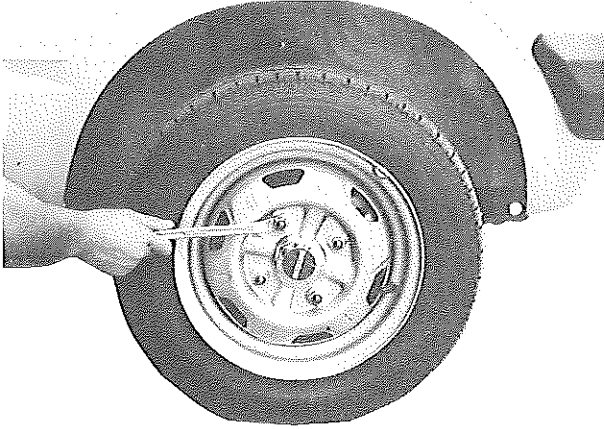

Fig. 15-2

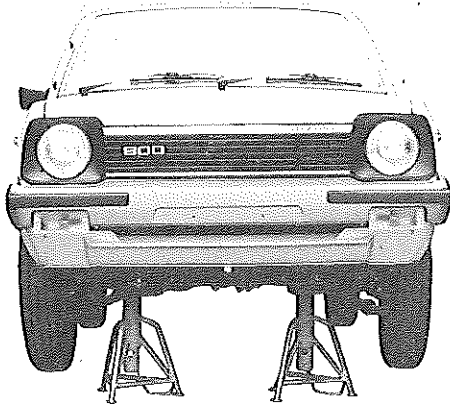

Fig. 15-3

- 3) Drain out oil in the transmission.

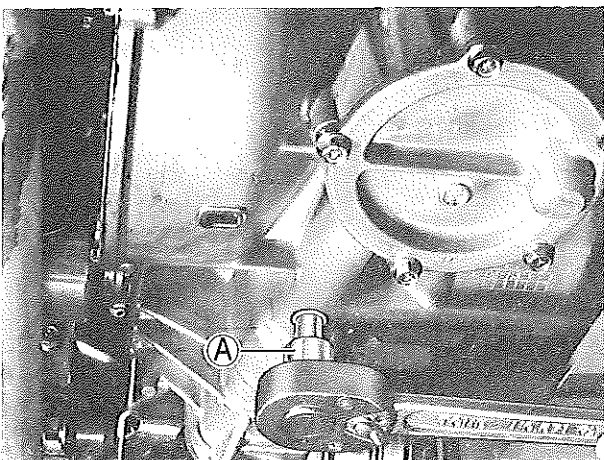

Fig. 15-4 Special tool Ⓐ (09915-27810)

- 4) Draw the drive shaft out of the snap ring fitted on the spline of the differential side gear.

**NOTE:**

At this stage, the drive shaft cannot be taken out from the side gear.

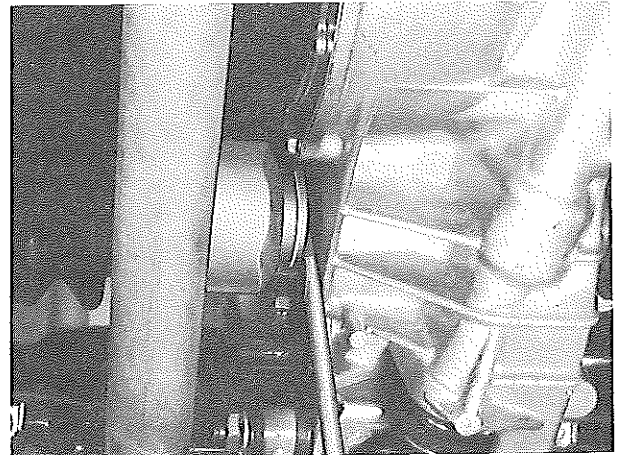

Fig. 15-5

- 5) Remove the drive shaft castle nut.
- 6) Detach the tie rod end from the steering knuckle by using special tool Ⓐ (09913-65210).

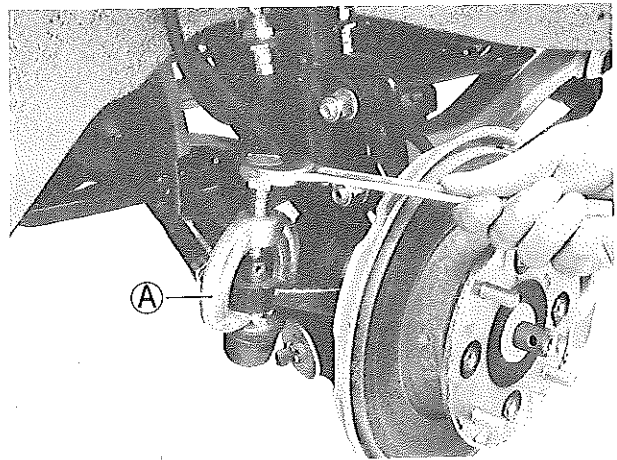
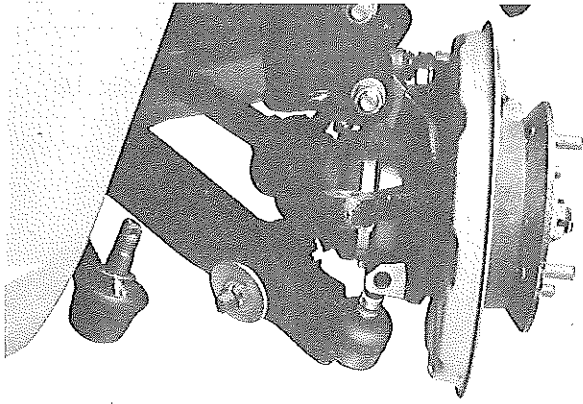

Fig. 15-6

- 7) Detach the front suspension arm ball joint stud from the steering knuckle.

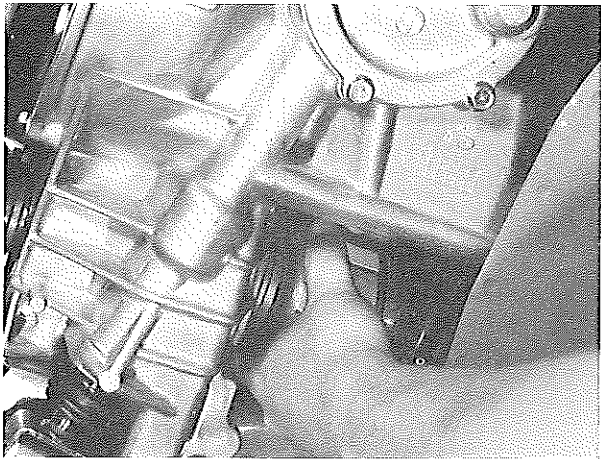

*Fig. 15-7*

- 8) Draw the drive shaft out of the differential side gear spline.

**CAUTION:**

At this time, be careful not to damage the brake flexible hose.



*Fig. 15-8*

- 9) After inserting the suspension arm ball joint stud to steering knuckle, fit nut ① on the drive shaft and tap the shaft from the outside to the inside with a plastic hammer.

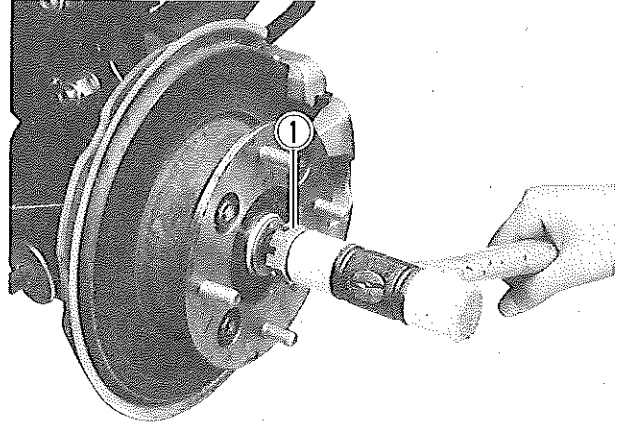

*Fig. 15-9*

### 15-3. Disassembly

Wipe the outer surface of the drive shaft with a cloth and disassembly in the following manner.

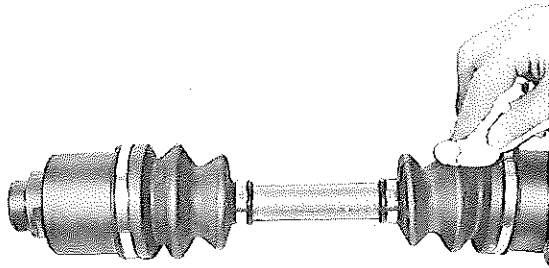

Fig. 15-10

Remove the boot band.

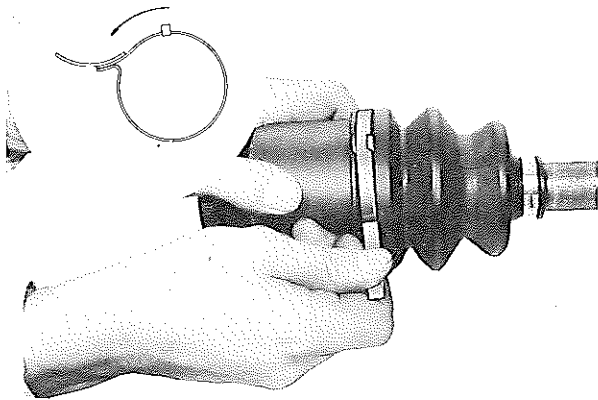

Fig. 15-11

Slide the boot toward the center of the shaft and remove the snap ring from the outer race.

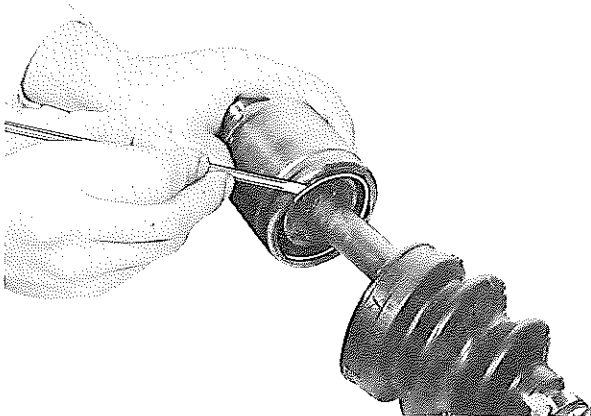

Fig. 15-12

Take the shaft off the outer race.

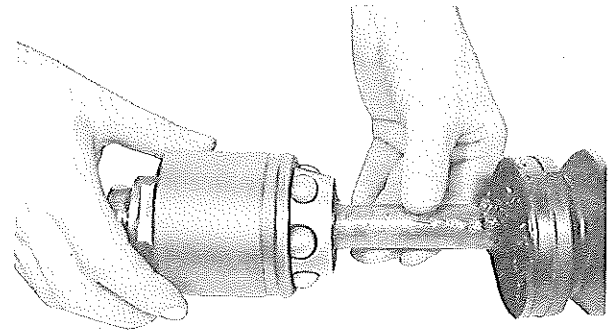

Fig. 15-13

Wipe off grease and remove the circlip fixing the cage, using a circlip remover (A) (09900-06107).

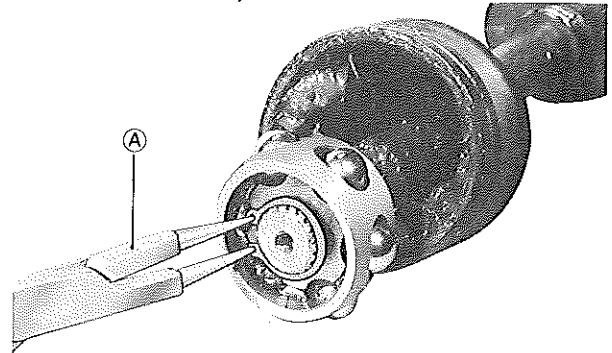

Fig. 15-14

Draw the cage and boot (inside or outside boot) off the shaft.

**NOTE:**  
Outside joint is not removable.

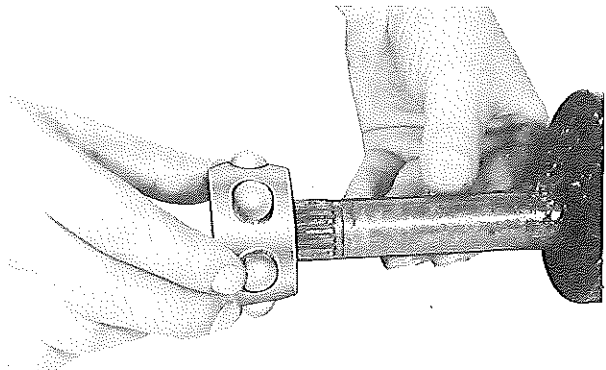

Fig. 15-15

### Barfield joint inspection

To be checked on this joint is its axial play, which shows up when a push-and-pull motion is given to the live axle shaft and wheel spindle held in both hands, as shown in Fig.15-16. There should be no play at all but a play of up to 1.5 mm (0.06 in.) is permissible. If the play exceeds the limit replace it.

	Standard	Service limit
Axial play in Barfield joint	0 mm (no play)	1.5 mm (0.06 in.)

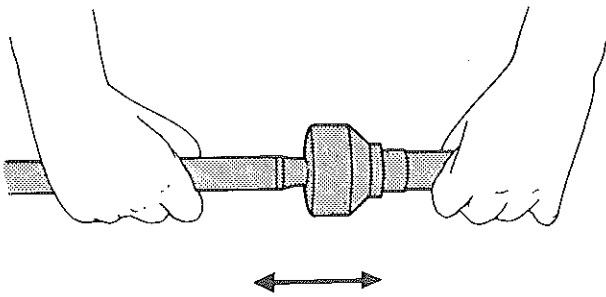

Fig. 15-16

## 15-4. Maintenance Services

- 1) Check the boots for breakage.
- 2) Inspect for abnormal noise at start or while running.
- 3) Jack up the car body and confirm that the drive shaft is free from play in the rotational direction and rotates smoothly.

When any defect is found, check the following points.

- Inspect the boots for breakage and replace if broken (inspect following points before replacement).
- Inspect contact condition of parts (wear) and replace if worn remarkably or damaged.
- Check each part for chips and cracks.
- Check the circlip and snap ring for deformation or breakage and replace when defective.

## 15-5. Installation Procedure

### CAUTION:

Wash all parts before installation. Wipe out the boot with a cloth.

Fit a boot on the drive shaft and, fitting the small diameter side of the boot to the shaft groove, fix with a boot band.

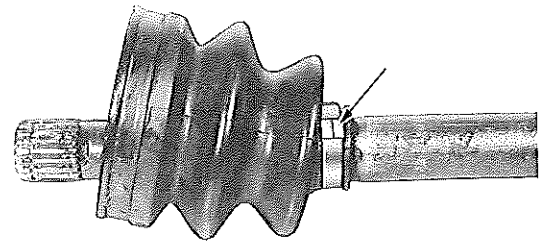

Fig. 15-17

Install the cage ① on the shaft.

### CAUTION:

Install the cage directing the smaller outside diameter side to the shaft end.

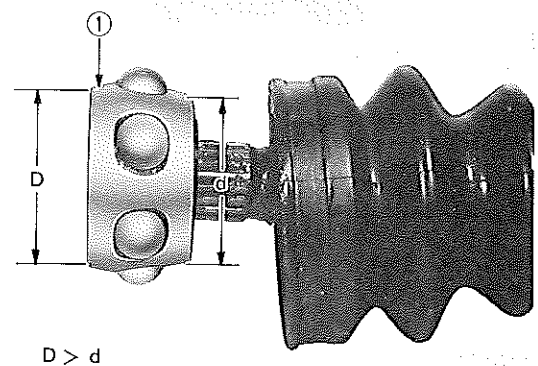
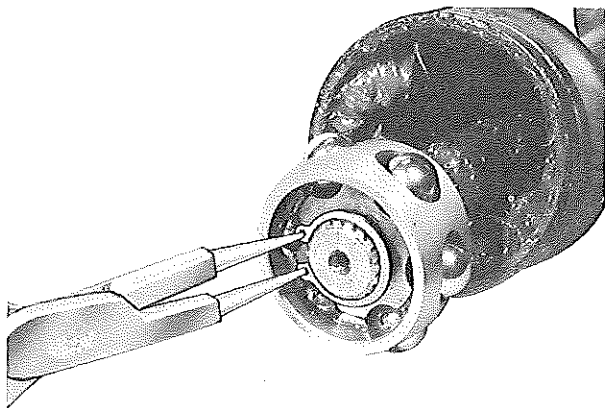

Fig. 15-18

Do not forget to fit a circlip when fitting the cage.



*Fig. 15-19*

Apply 30 - 50 g (1.06 - 1.76 oz) SUZUKI SUPER GREASE H (C.V. joint grease) to entire surface of the cage.

SUZUKI SUPER GREASE H  
(C.V. joint grease) (99000 - 25120)

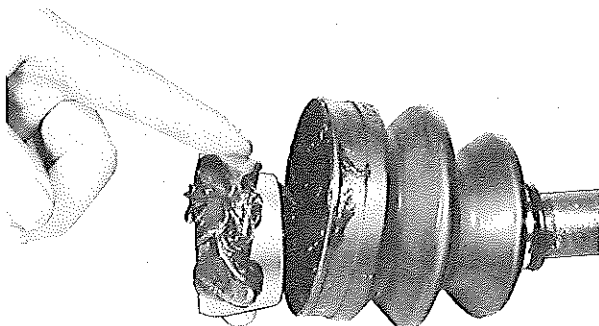
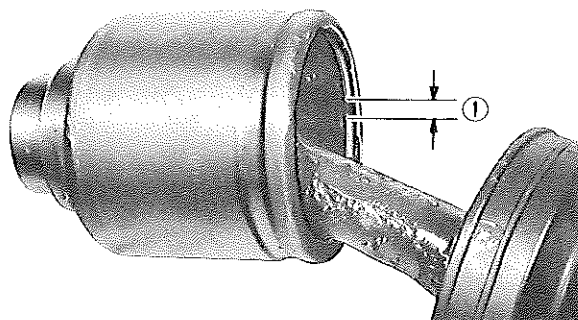

*Fig. 15-20*

Insert the cage into the outer race and fit a snap ring in the groove of the outer race.

**CAUTION:**

Locate the opening of the snap ring ① so that the opening is not lined up with a ball.



*Fig. 15-21*

Apply 30 - 40 g (1.06 - 1.41 oz) SUZUKI SUPER GREASE H (99000 - 25120) to the inside of the outer race, and fit the boot on the outer race.

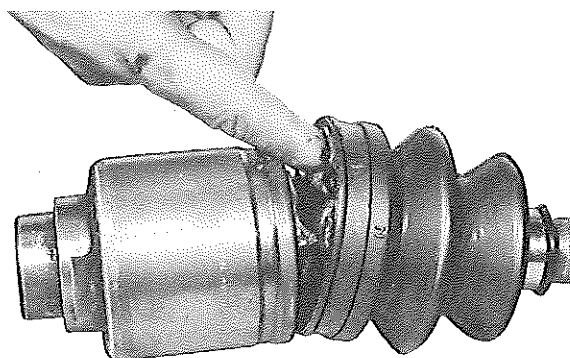

*Fig. 15-22*

After fitting the boot, insert a driver into the boot on the outer race side and allow air to enter the boot so that the air pressure in the boot becomes the same as the atmospheric pressure at the positions indicated in Fig. 15-23.



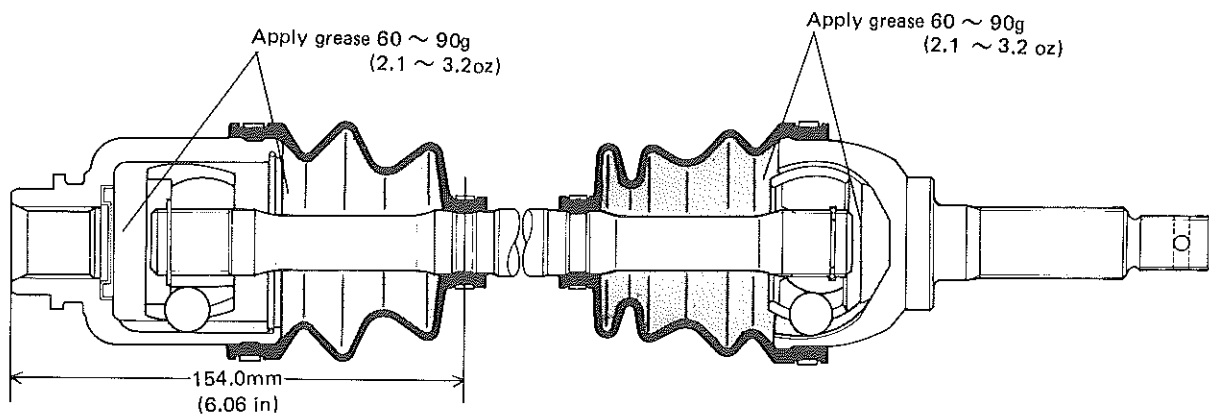

Fig. 15-23

Fix the boot to the outer race with a boot band, taking care not to distort the boot.

Use special tool Ⓐ (09922 - 55121) to install the drive shaft in the steering knuckle, and draw the drive shaft from inside to outside.

**CAUTION:**

- Before inserting the drive shaft into the spline of the differential side gear, make certain that a snap ring has been fitted to the spline. Then insert the drive shaft until it is positioned by the snap ring.
- Never tap the boot when inserting the drive shaft as this may damage the boot.

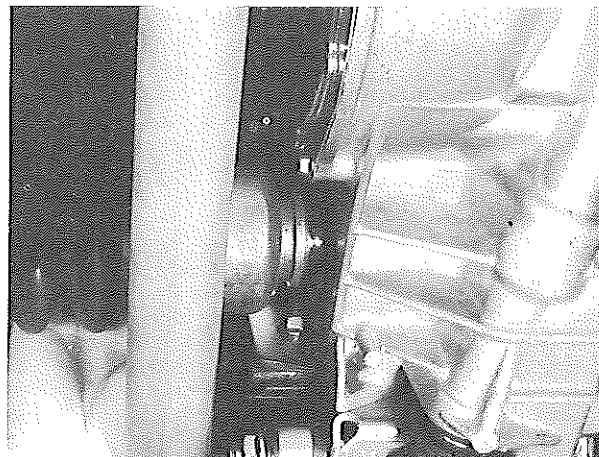

Fig. 15-25

Reassemble remaining parts in the reverse order to disassembly.

**CAUTION:**

- Tighten the drive shaft castle nut and hub nuts to the specified torque.
- Tighten the ball joint stud bolt to the specified torque.
- Do not forget to lubricate the transmission. Refer to the item on transmission (group 14) for the specified oil.

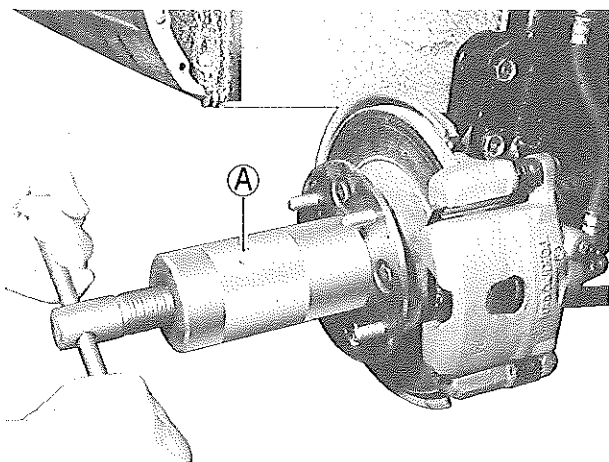

Fig. 15-24

