

6. AIR CLEANER, FUEL PUMP AND FUEL FILTER

6-1.	Air Cleaner	6-2
6-2.	Fuel Pump	6-4
6-3.	Fuel Filter	6-5

6-1. Air Cleaner

Servicing

This air cleaner element is of dry type. Remember that it needs cleaning according to the following method and interval.

- 1) Take out the cleaner element ① off the air cleaner case.

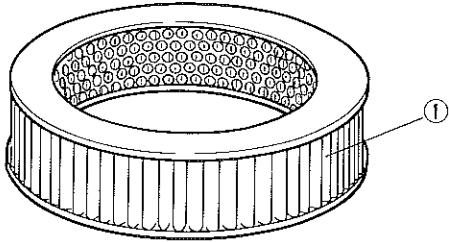

Fig. 6-1

- 2) Blow off dust by compressed air from inside of element.

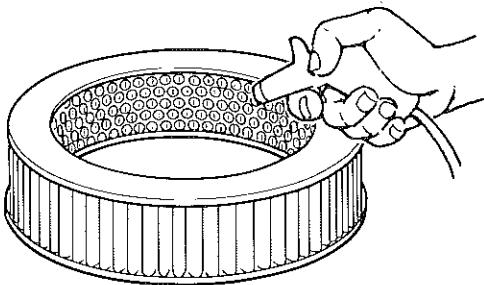

Fig. 6-2

NOTE:

If the element are heavily dirtied, wash it in household type detergent. After washing, rinse the detergent out of element, and dry it completely.

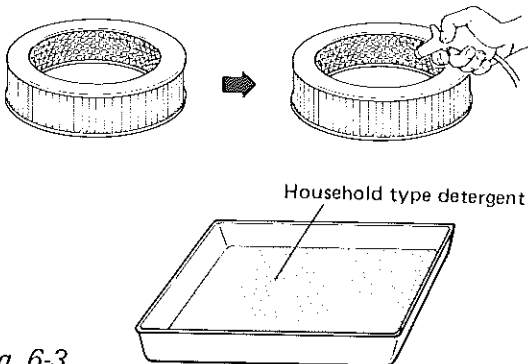

Fig. 6-3

Clean	Paved-road: Every 10,000 km (6,000 miles)
	Dusty condition: Every 2,500 km (1,500 miles) or as required
Replace	Every 40,000 km (24,000 miles)

NOTE:

More frequent replace if under dusty driving conditions.

Air cleaner case

When installing the air cleaner case cap, align the arrow marks ① and ② .

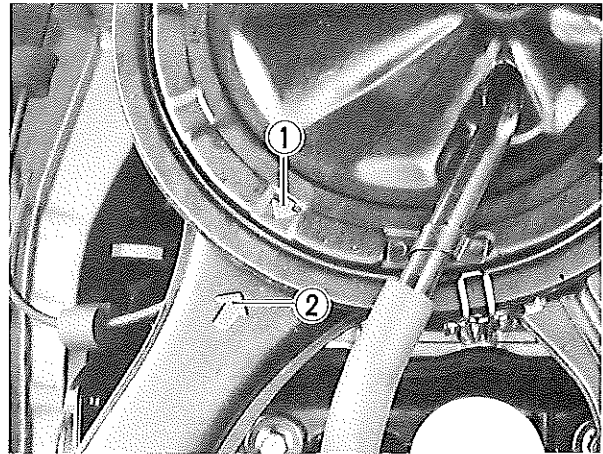

Fig. 6-4

Use of the selector lever

A mispositioned selector lever can cause the carburetor to get "iced" in freezing weather or the engine to overheat in hot weather. Position this lever according to the atmospheric temperature, i.e., in WINTER position when outside temperature is 15°C (59°F) or below, or in SUMMER position when the temperature is above that level.

Warm-air selector lever position	
Atmospheric temperature	Lever position
15°C (59°F) or below	WINTER
Above 15°C (59°F)	SUMMER

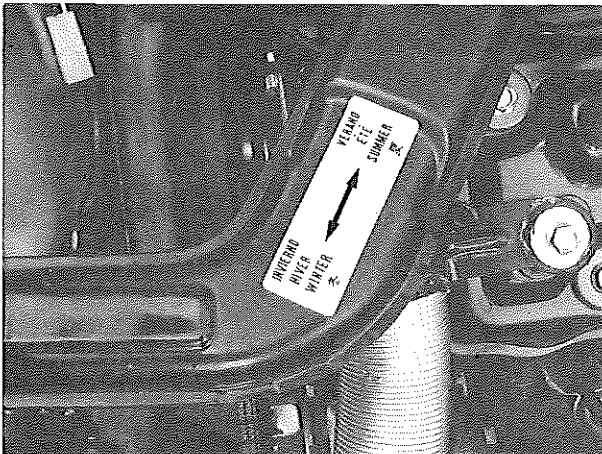

Fig. 6-5

6-2. Fuel Pump.

Description

A pneumatic diaphragm pump is used to deliver gasoline to the float chamber in the carburetor. Its diaphragm is actuated from one of the cams formed of engine camshaft. A rocker arm rides on this cam and moves the pump diaphragm up and down.

As this fuel pump is of non-disassembly type, replace it as an assembly unit if it is not in good condition.

Fuel pump specifications	
Discharge pressure	0.20 - 0.30 kg/cm ² (2.85 - 4.27 psi)
Pump capacity	0.2 litres/minute or better at 2,000 r/min

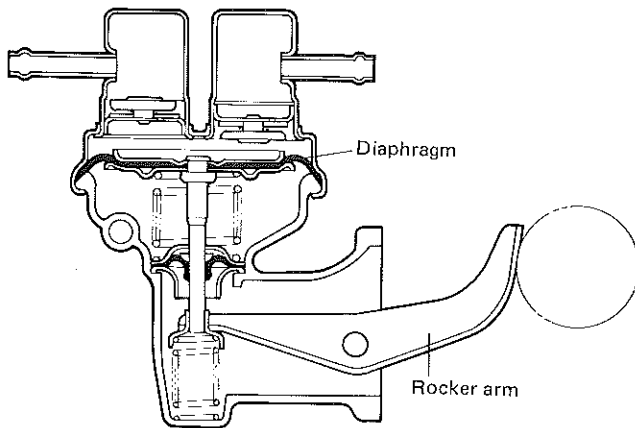

Fig. 6-6

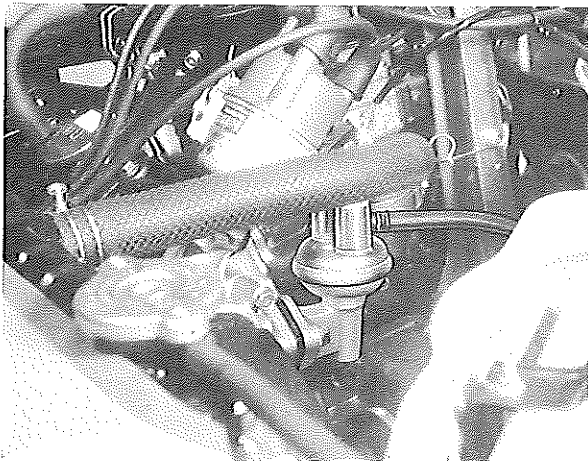

Fig. 6-7

Removal

- 1) Disconnect the inlet and outlet hoses from the fuel pump body.
- 2) Remove the fuel pump by loosening the two bolts.

CAUTION:

Engine oil will come out of the distributor drive gear case when the fuel pump is removed from the case. Never allow this oil to find its way into the transmission case.

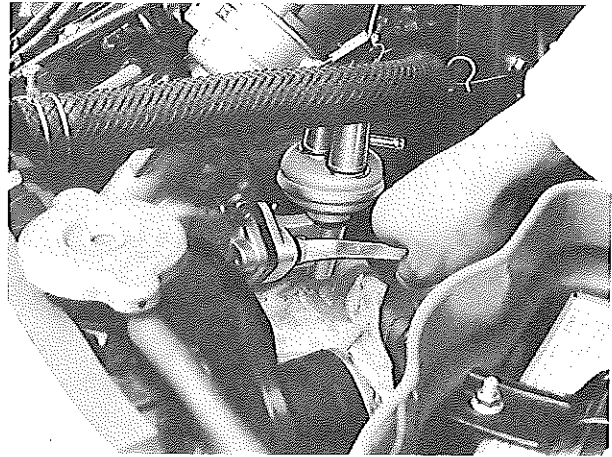

Fig. 6-8

Inspection

- Check the fuel pump diaphragm for breakage. The diaphragm is in good condition if there is no evidence of gasoline leakage where the fuel pump is installed. (See Fig. 6-9)

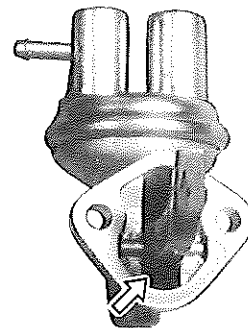

Fig. 6-9

- Check where the rocker arm of the fuel pump and the cam of the camshaft contact for uneven wear.

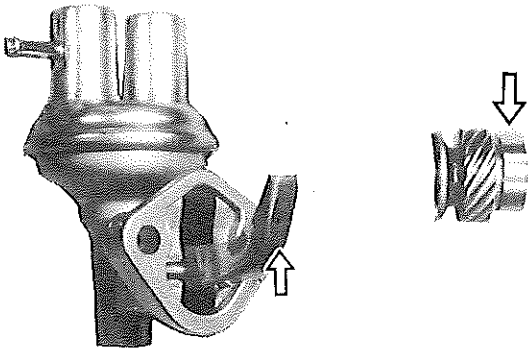

Fig. 6-10

Important step in installation

When piping the fuel pipe after installation of the fuel pump, connect the hose coming from the fuel filter with the pipe on the "IN" marked side of the surge tank.

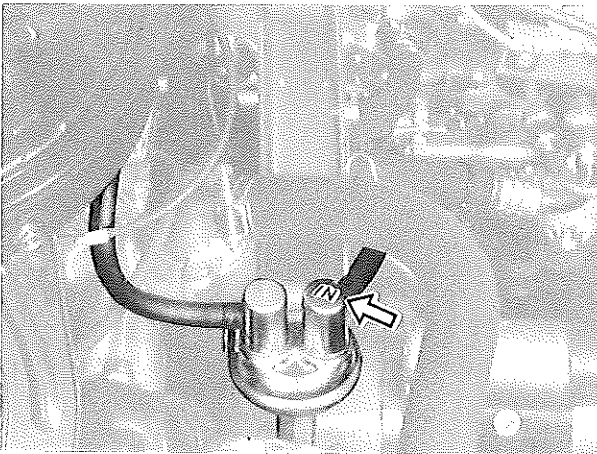

Fig. 6-11

6-3. Fuel Filter

Description

Fuel enters the filter through its inlet hole and, after passing through the filtering element, comes out of its outlet hole communicated to the fuel pump. This filter can be disassembled.

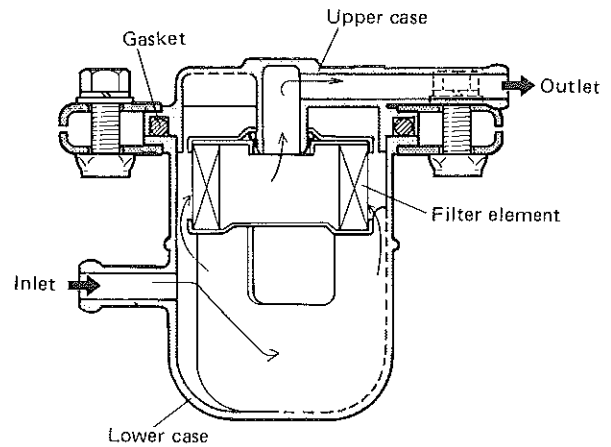

Fig. 6-12

Servicing and installation

Clean or replace this fuel filter element periodically according to the following.

Clean	Every 10,000 km (6,000 miles)
Replacement	Every 40,000 km (24,000 miles)

[Fuel filter element cleaning and replacing]

- Separate fuel filter to upper case and lower case and air-blow to clean upper case from its outlet pipe side, and also clean the lower case inside.

NOTE:

Do not separate filter element and filter upper case at this point.

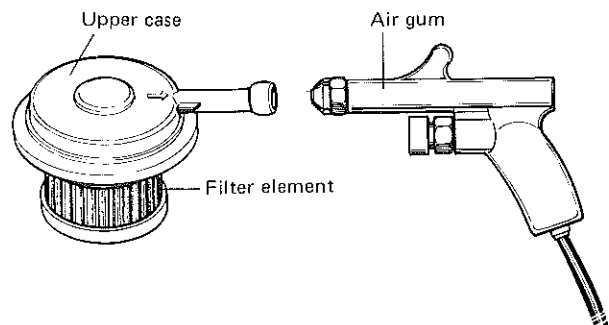

Fig. 6-13

NOTE:

- Whenever replacing the fuel filter element, replace the gasket, and then clean the lower case inside.
- When putting together upper case and lower case, pay attention to direction of outlet pipe and inlet pipe.
- Make sure that matching marks on the fuel filter case and plate match accurately before tightening.
- Each of 3 screws should be tightened uniformly and sequentially at the same torque.

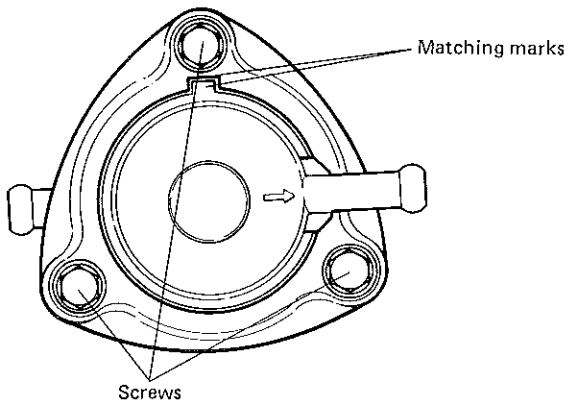

Fig. 6-14

WARNING:

After installing fuel filter, check to ensure that there is no leakage of gasoline.

Fig. 6-15, shows the fuel filter in its correct posture, with outlet ① coming on top side and inlet ② on bottom side. Remember the relative positions of inlet and outlet when piping the filter.

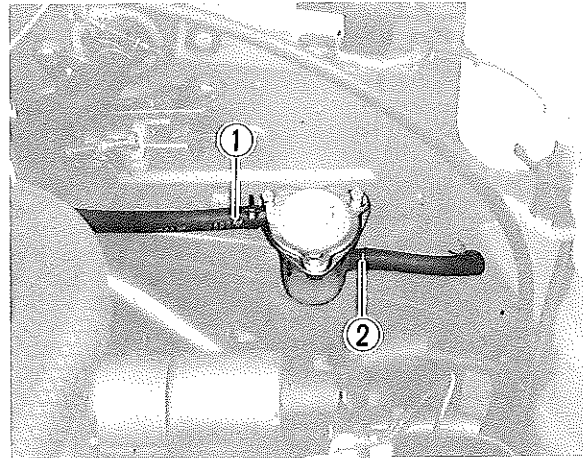

Fig. 6-15