

TABLE OF CONTENTS

GENERAL	1
SERVICE DATA	2
TROUBLE SHOOTING	3
ENGINE	4
CARBURETOR	5
AIR CLEANER, FUEL PUMP AND FILTER	6
ENGINE COOLING SYSTEM	7
CAR HEATER	8
IGNITION SYSTEM	9
STARTER MOTOR	10
CHARGING SYSTEM	11
CLUTCH	12
GEAR SHIFTING CONTROL	13
TRANSMISSION AND DIFFERENTIAL	14
DRIVE SHAFTS	15
SUSPENSION	16
STEERING SYSTEM	17
BRAKES	18
BODY	19
BODY ELECTRICAL EQUIPMENT	20
PERIODICAL INSPECTION SCHEDULE	21

10/10/10

10/10/10

10/10/10

10/10/10

10/10/10

10/10/10

10/10/10

10/10/10

10/10/10

1. GENERAL

1-1. Exterior View	1-2
1-2. Specifications	1-3
1-3. Locations of Engine Number and Body Number	1-7
1-4. Standard Shop Practices	1-8
1-5. Special Tools	1-10
1-6. Required Materials.	1-13

1-1. Exterior View

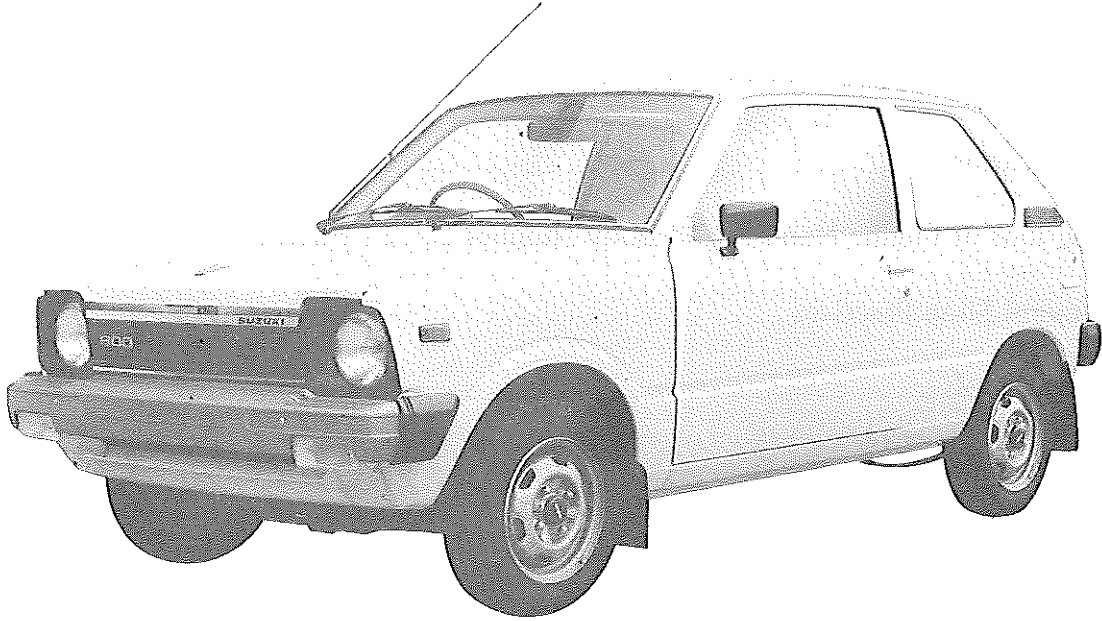

(The photo shows standard specification.)

1-2. Specifications

Item	MODEL	HATCH
DIMENSION		
Overall length		3,295 mm (129.7 in.)
Overall width		1,405 mm (55.3 in.)
Overall height		1,340 mm (52.8 in.)
Wheelbase		2,150 mm (84.6 in.)
Tread:	Front	1,215 mm (47.8 in.)
	Rear	1,170 mm (46.1 in.)
Load deck size:		
	Length	955 mm (37.6 in.)
	Width	1,180 mm (46.5 in.)
	Height	775 mm (30.5 in.)
Ground clearance		175 mm (6.9 in.)
WEIGHT		
Curb weight		600 kg (1,323 lbs)
Weight distribution:		
	Front	380 kg (838 lbs)
	Rear	220 kg (485 lbs)
Gross vehicle weight		950 kg (2,094 lbs)
Seating capacity		2 persons
Maximum loading capacity		350 kg (772 lbs) including 2 persons
ENGINE		
Type		4-stroke cycle, water cooled, OHC
Number of cylinders		3
Lubrication system		Wet sump
Bore		68.5 mm (2.70 in.)
Stroke		72.0 mm (2.83 in.)
Piston displacement		796 cm ³ (796 cc, 48.6 cu-in.)
Compression ratio		8.7 : 1
Carburetor		MIKUNI DIDS 2430, single
Air cleaner		Dry type

Item	MODEL	HATCH
ELECTRICAL		
Ignition timing		7° B.T.D.C. below 900 r/min (rpm)
Standard spark plug		NGK BP5ES NIPPON DENSO W16EX-U
Starter		Magnetic shift type
Generator		Alternator
Battery		NS40S type : 12V 108 kC (30 AH)/20 HR NT60-S4 type : 12V 126 kC (35 AH)/20 HR
Headlight		12V 50/40W
Turn signal light		12V 21W
Clearance light		12V 5W
Parking light		12V 5W
Tail/Brake light		12V 5/21W
Side turn signal light		12V 6W
License plate light		12V 10W
Back up light		12V 21W
Interior light		12V 6W
Meter pilot lights		12V 3.4W
Main fuse		30A
Fuse box		10A, 10A, 15A, 15A, 15A, 15A
POWER TRANSMISSION		
Clutch type		Dry, single disc
Transmission type		4-forward all synchromesh, 1 reverse
Final reduction ratio		4.350
Gear ratios:	Low	3.583
	2nd	2.166
	3rd	1.333
	Top	0.900
	reverse	3.363
WHEEL AND SUSPENSION		
Tire size: Front and rear		145/70 SR12 (Tubeless tire)
Tire pressure	Front	190 kPa (1.9 kg/cm ² , 27 psi)
	Rear	220 kPa (2.2 kg/cm ² , 31 psi)
Suspension type, front		Strut
rear		Leaf spring

Item	MODEL	HATCH
STEERING		
Turning radius		4.4 m (14.4 ft)
Steering gear box		Rack and pinion
Toe-in		2 ~ 4 mm (0.079 ~ 0.157 in.)
Camber angle		1° 20'
Caster angle		3° 15'
Trail		13 mm (0.51 in.)
King pin angle		12° 50'
BRAKE SYSTEM		
Type		4-wheel, hydraulic
Wheel brake	Front	Disc brake
	Rear	Leading and trailing
Parking brake		Mechanical, 2-rear wheels
CAPACITIES		
Cooling solution		3.6 ℓ (7.6/6.3 US/Imp pt)
Fuel tank		27.0 ℓ (7.1/5.9 US/Imp gal)
Engine oil		2.5 ℓ (5.3/4.4 US/Imp pt)
Transmission oil		2.0 ℓ (4.2/3.5 US/Imp pt)

1-3. Locations of Engine Number and Body Number

The engine number is punched on the skirt part of the cylinder block under the carburetor.

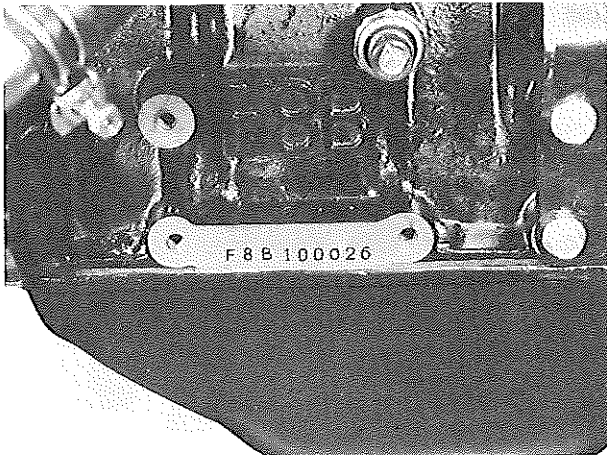

Fig. 1-1 Location of Engine No.

The body number is punched on the body in the engine room as shown below.

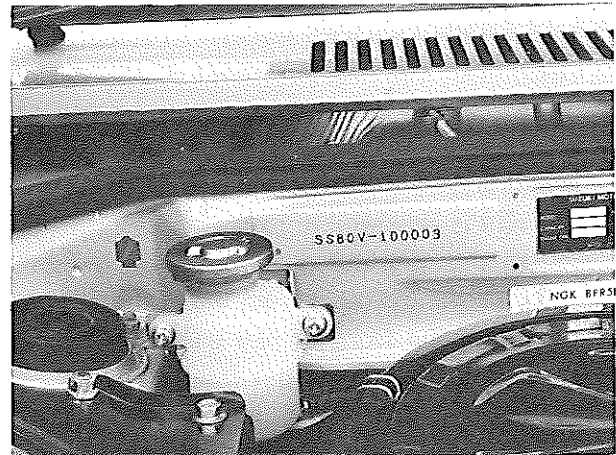

Fig. 1-2 Location of Body No.

1-4. Standard Shop Practices

1. Protect the painted surfaces of the body, and avoid staining or tearing the seats. When working on the fenders and seats, be sure to cover them up with sheets.
2. Disconnect the negative terminal connection of the battery when working on any electrical part or component. This is necessary for avoiding electrical shocks and short-circuiting, and is very simple to accomplish: merely loosen the wing nut on the negative terminal and separate the cable from the terminal post.
3. In raising the front or rear end off the floor by jacking, be sure to put the jack up against the center portion of the rear axle housing or front suspension frame.

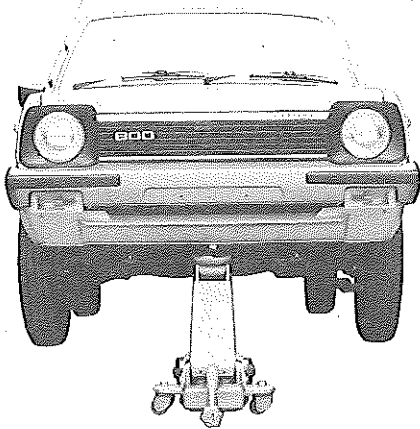

Fig. 1-3

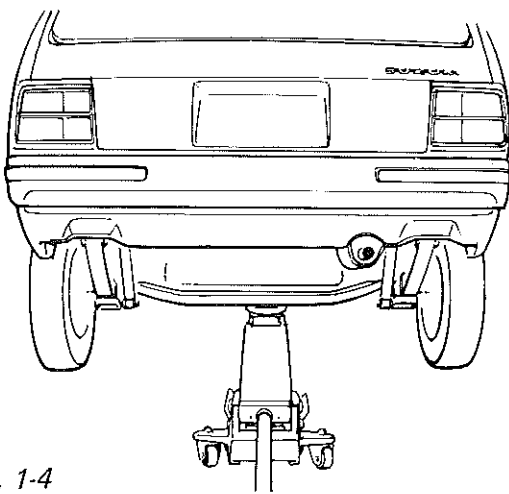

Fig. 1-4

4. To work on the front or rear end raised by jacking, be sure to place the safety stand under the front suspension frame or rear axle to support it in stable condition.



Fig. 1-5

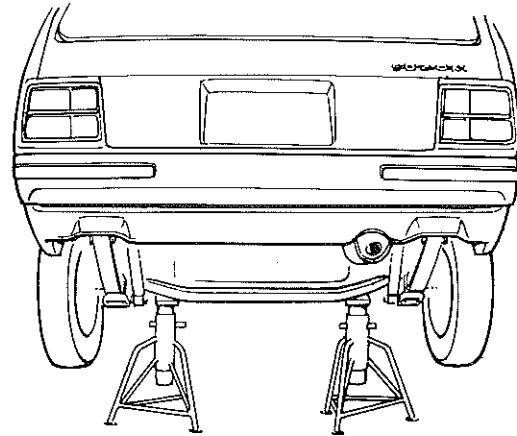

Fig. 1-6

5. Have wheel chocks for ready use in the shop. Chock the wheels securely when raising one end of the machine.
6. Orderliness is a key to successful overhauling. Trays, pans and shelves are needed to set aside the disassembled parts in groups or sets in order to avoid confusion and misplacement. This is particularly important for engine overhauling.
7. Have on hand the liquid packing - SUZUKI BOND No. 4 (99000-31030) - for ready use. This packing dope is an essential item assures leak-free (water and oil) workmanship.

8. Each bolt must be put back to where it was taken from or for which it is intended. Do not depend on your hunch in tightening the bolts for which tightening torque values are specified: be sure to use torque wrenches on those bolts.
9. It is advisable to discard and scrap gaskets and "O" rings removed in disassembly. Use new ones in reassembly, and try not to economize gaskets and "O" rings.
10. Use of Genuine SUZUKI parts is imperative. Use of imitation parts is a big gamble on safety and performance. Use Genuine SUZUKI parts and live up to the trust your customer places on you.
11. Special tools save time and ensure good workmanship: They are available from SUZUKI. Use them where their use is specified. Moreover, your own safety is assured by the use of special tools in many of the disassembly and reassembly steps.
12. Refer to the contents of this MANUAL as often as practical, and do each job right as prescribed.

NOTE:

The engine cylinders are identified by numbers. See Fig. 1-7. Counting from the crankshaft pulley side, the cylinders are referred to as No. 1, No. 2 and No. 3 cylinders.

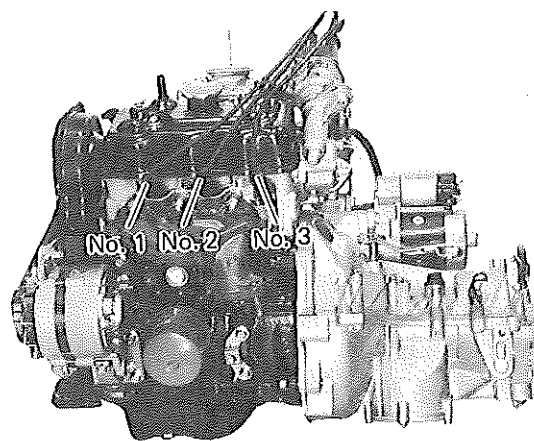
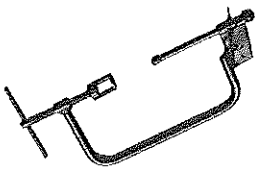
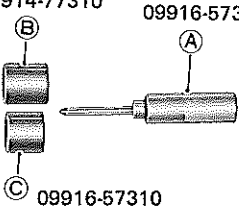
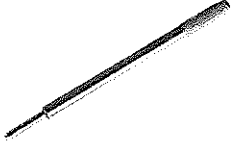
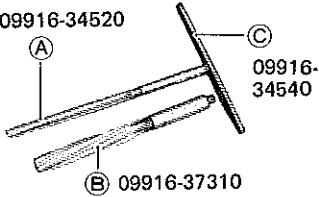
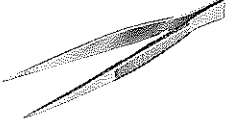
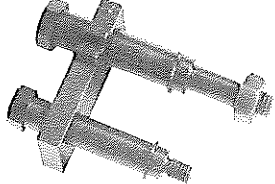
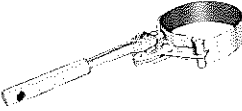
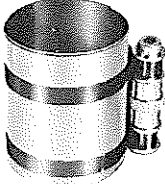
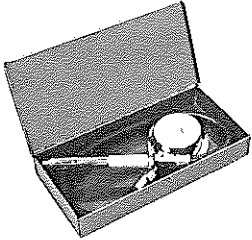
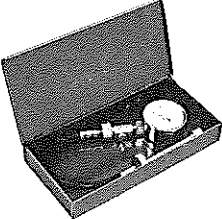
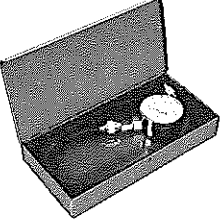
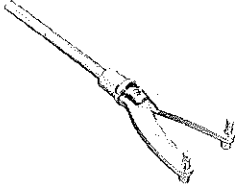
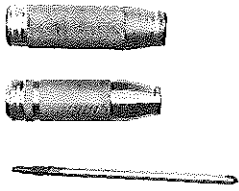
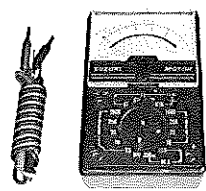
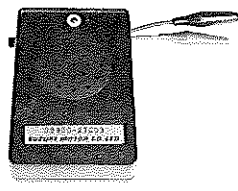
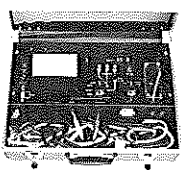
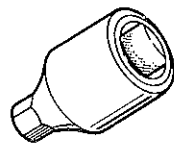
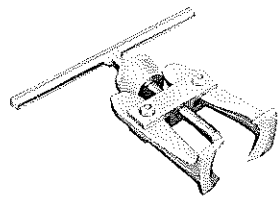
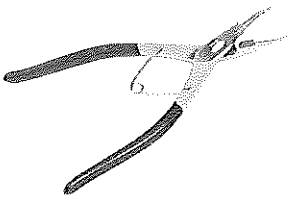
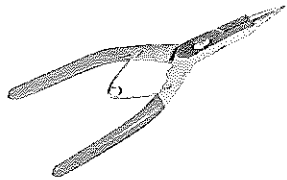
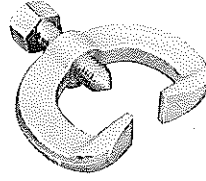
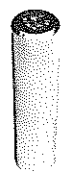
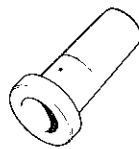
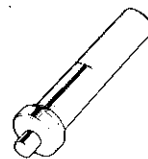
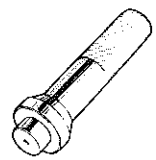
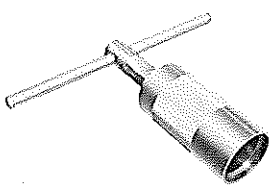
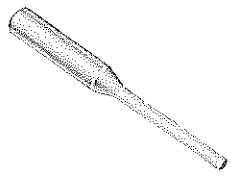

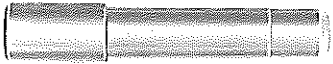
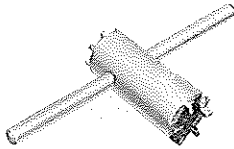
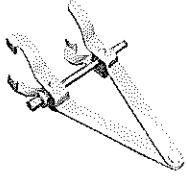
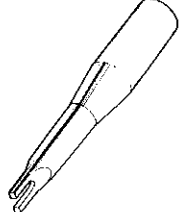

Fig. 1-7 Engine cylinder numbers

1-5. Special Tools

Special tools assure three things: 1) improved workmanship; 2) speedy execution of jobs for which they are meant; and 3) protection of parts and components against damage. Here are the special tools prescribed for this Model:



<p>1.</p>  <p>09916-14510 Valve lifter</p>	<p>2.</p>  <p>09914-77310 09916-57320 09916-57310</p> <p>(A) Valve guide & valve stem seal handle (B) Valve stem seal installer attachment (C) Valve guide installer attachment</p>	<p>3.</p>  <p>09916-44510 Valve guide remover</p>
<p>4.</p>  <p>09916-34520 09916-34540 09916-37310</p> <p>Valve guide reamer (A) 7 mm dia (B) 12.0 mm dia (C) Handle</p>	<p>5.</p>  <p>09916-84510 Forceps</p>	<p>6.</p>  <p>09916-97820 Flywheel stopper</p>
<p>7.</p>  <p>09915-47310 Oil filter wrench</p>	<p>8.</p>  <p>09916-77310 Piston ring compressor</p>	<p>9.</p>  <p>09915-77310 (09915-77610) Oil pressure gauge (Attachment)</p>
<p>10.</p>  <p>09915-64510 Compression gauge</p>	<p>11.</p>  <p>09915-67310 Vacuum gauge</p>	<p>12.</p>  <p>09930-40113 Camshaft lock holder</p>

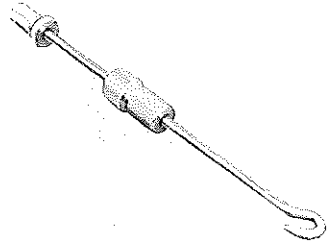
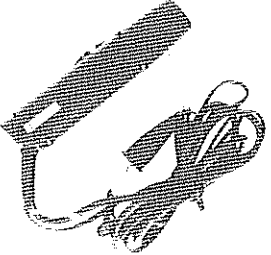

<p>13.</p>  <p>09900-09002 Shock driver set</p>	<p>14.</p>  <p>09900-25002 Pocket tester</p>	<p>15.</p>  <p>09900-27003 Ignition timing tester</p>
<p>16.</p>  <p>09900-28106 Electro tester</p>	<p>17.</p>  <p>09915-27810 Hexagon socket (10 mm)</p>	<p>18.</p>  <p>09913-61110 Bearing puller</p>
<p>19.</p>  <p>09900-06108 Snap ring pliers (closing type)</p>	<p>20.</p>  <p>09900-06107 Snap ring pliers (opening type)</p>	<p>21.</p>  <p>09913-65210 Tie-rod end puller</p>
<p>22.</p>  <p>09913-80112 Bearing installer</p>	<p>23.</p>  <p>09913-75810 Bearing installer</p>	<p>24.</p>  <p>09913-75820 Steering pinion bearing installer</p>
<p>25.</p>  <p>09913-75830 Steering pinion bush installer</p>	<p>26.</p>  <p>09922-55121 Drive shaft installer</p>	<p>27.</p>  <p>09922-85811 Spring pin remover</p>

<p>28.</p>  <p>09923-37810 Clutch center guide</p>	<p>29.</p>  <p>09942-45810 Steering plug setting tool</p>	<p>30.</p>  <p>09943-25810 Coil spring setting tool</p>
<p>31.</p>  <p>09913-17310 Carburetor adjuster</p>	<p>32.</p>  <p>09943-17910 Front wheel hub remover</p>	<p>33.</p>  <p>09942-15510 Sliding hammer</p>
<p>34.</p>  <p>09900-27301 Timing light</p>		

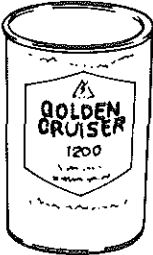
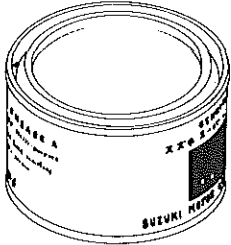
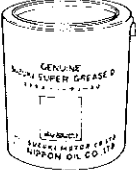
1-6. Required Materials

The materials listed below are needed for maintenance work on this vehicle, and should be kept on hand for ready use. In addition, such standard materials as cleaning fluids, lubricants, etc., should also be available. Methods and time of use are discussed in the text of this manual on later pages.

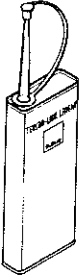
Ref. No.	Material	Use
1.	<p>GOLDEN CRUISER 1200 "Anti-freeze and Summer Coolant" (99000-24120)</p> 	<p>Additive to engine cooling for improving cooling efficiency and for protection of wet walls against rusting.</p>
2.	<p>SUZUKI SUPER GREASE A (99000-25010)</p> 	<ul style="list-style-type: none"> ● For locations indicated in the section dealing with the starter motor. ● Clutch release bearing retainer. ● Clutch release shaft bushing. ● Transmission oil seal. ● Differential oil seal. ● Steering column. ● Gear shifting control lever bushing & seat. ● Door window regulator.
3.	<p>SUZUKI GREASE SUPER H (99000-25120)</p> 	<p>Special grease intended for use on constant velocity joint. (Drive shaft joint)</p>
4.	<p>SUZUKI BOND (No. 4) (99000-31030)</p> 	<ul style="list-style-type: none"> ● For top and bottom mating faces of transmission case. ● For other locations specifically indicated in the text of this manual.

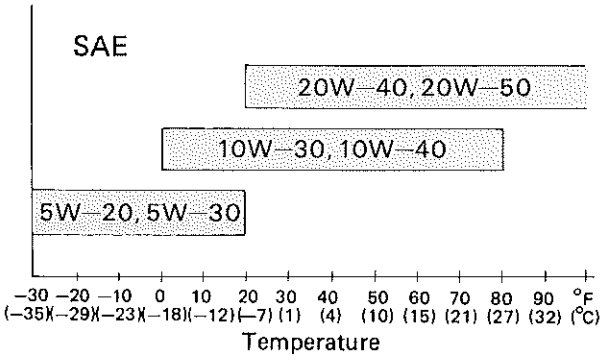
5.	<p>THREAD-LOCK CEMENT (99000-32040)</p> 	<ul style="list-style-type: none"> ● Timing belt inside cover bolt ● Back window hinge screws
6.	<p>SUZUKI SUPER GREASE E (99000-25050)</p> 	<ul style="list-style-type: none"> ● Steering gear case ● Steering rack ● Steering pinion bush ● Steering rack boot
7.	<p>WHEEL BEARING GREASE</p>	<ul style="list-style-type: none"> ● Rear axle spindle cap ● Front wheel bearing ● Rear wheel bearing
8.	<p>GEAR OIL SAE # 90</p>	<ul style="list-style-type: none"> ● Transmission case 2.0 ltr. (4.2/3.5 US/Imp. pt.) ● Transmission gear and bearing.
9.	<p>4-STROKE ENGINE OIL</p> <p>Proper oil viscosity chart</p>  <p>The chart shows three recommended oil grades based on temperature ranges:</p> <ul style="list-style-type: none"> 5W-20, 5W-30 for temperatures from -30°F to 30°F (-35°C to 10°C) 10W-30, 10W-40 for temperatures from 0°F to 70°F (-18°C to 21°C) 20W-40, 20W-50 for temperatures from 30°F to 90°F (10°C to 32°C) 	<ul style="list-style-type: none"> ● For engine oil pan: 2.5 litres (5.3/4.4 US/Imp. pt.) for periodical oil change but 3.0 litres (6.3/5.3 US/Imp. pt.) for refilling at the time of engine overhauling. ● Crank journal bearings and thrust plate. ● Connecting-rod big-end and small-end bearings. ● Camshaft journals and thrust plate. ● Rocker shafts. ● Oil pump gears. ● Pistons and piston rings. ● Engine oil seals. ● Valve stems. ● Accelerator, choke and clutch cables. ● Parking brake cable. ● Accelerator, brake and clutch pedals. ● Door locks and hinges. ● Distributor gear.

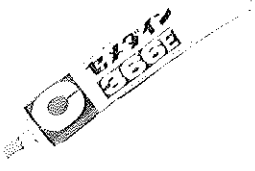
10.	SEALING COMPOUND 366E (99000-31090) 	<ul style="list-style-type: none"> ● Brake backing plate
11.	THREAD LOCK CEMENT SUPER 1342 (99000-32050)	<ul style="list-style-type: none"> ● Timing belt tensioner bolt
12.	BRAKE FLUID "DOT 3, DOT 4" or SAE J1703	<ul style="list-style-type: none"> ● Brake fluid reservoir tank

